

# Tarn

Designed by the Berroco Design Team / Skill level: Intermediate



## FINISHED MEASUREMENTS

Bust: 36 (40, 44, 48, 52, 56, 60)"

Length: 22½ (23, 23½, 24, 24, 24½, 24½)"

Shown in size 40". Suggested ease: 2–5" positive ease.

## MATERIALS

**BERROCO VINTAGE DK** (100 grs):

4 (5, 6, 6, 7, 7, 8) hanks #2155

Delphinium

Knitting needles, sizes 6 (4.00 mm) and 7 (4.50 mm) *or size to obtain gauge*

24" length circular needle, size 6 (4.00 mm)

1 stitch marker

1 stitch holder

## GAUGE

22 sts and 30 rows = 4" in charted pattern on larger needles after blocking

*To save time and ensure accurate measurements, take time to check gauge.*

## Berroco Vintage® DK

Find this Yarn 



# BERROCO®



[www.berroco.com](http://www.berroco.com)

*We recommend using yarns called for in our instructions. Every effort has been made to ensure that directions contained in this book are accurate and complete, however errors do occur. We cannot be responsible for variance of individual knitters, human or typographical errors.*

*All pattern PDFs are updated when corrections are made. In the event of finding an error, please make sure you've downloaded the most recent version.*

## PATTERN STITCH

Multiple of 3 sts + 5.

**Row 1 (RS):** K1, \* k2, p1, rep from \* to last 4 sts, k2, p1, k1.

**Row 2:** P2, k1, p1, \* p1, k1, p1, rep from \* to last stitch, p1.

**Row 3:** K1, \* p1, k2, rep from \* to last 4 sts, p1, k3.

**Row 4:** P1, k1, p2, \* k1, p2, rep from \* to last stitch, p1.

**Row 5:** K1, \* k1, p1, k1, rep from \* to last 4 sts, k1, p1, k2.

**Row 6:** P3, k1, \* p2, k1, rep from \* to last stitch, p1.

Rep these 6 rows for Pattern Stitch.

## BACK

With smaller needles, 98 (110, 122, 134, 143, 155, 167) sts.

Knit 1 row on WS. Change to larger needles and work even, following chart or pattern stitch directions above, until piece measures 14" from beginning, end on WS.

**Shape Armholes:** Cast on 6 sts at beginning of the next 2 rows—110 (122, 134, 146, 155, 167, 179) sts. Working cast-on sts into pattern, work even until armholes measure 6½ (7, 7½, 8, 8, 8½, 8½)", end on WS.

**Shape Shoulders:** Bind off 4 (5, 6, 6, 7, 8, 8) sts at beginning of the next 8 rows, end on WS—78 (82, 86, 98, 99, 103, 115) sts. Mark center 40 (40, 40, 40, 41, 41, 41) sts on last row.

**Shape Neck: Next Row (RS):** Bind off 5 (4, 6, 6, 6, 8, 8) sts, work to first marker, slip stitches just worked to holder for right side; bind off center 40 (40, 40, 40, 41, 41, 41) sts, removing markers, work to end—19 (21, 23, 29, 29, 31, 37) sts.

**Left Shoulder: Next Row (WS):** Bind off 5 (4, 6, 6, 6, 8, 8) sts work to end—14 (17, 17, 23, 23, 23, 29) sts. Dec 1 st at neck edge at beginning of the next row, then at beginning of every RS row once more. AT THE SAME TIME, bind off 4 (5, 5, 7, 7, 7, 9) sts at armhole edge 3 times more. Fasten off.

**Right Shoulder:** With WS facing, slip 14 (17, 17, 23, 23, 23, 29) sts from holder to larger needle. Join yarn and work 1 WS row. Bind off 4 (5, 5, 7, 7, 7, 9) sts at armhole edge 3 times. AT THE SAME TIME, dec 1 st at neck edge every RS row twice. Fasten off.







## FRONT

Work as for back until 6 sts have been cast on at each edge for armholes, end on WS—110 (122, 134, 146, 155, 167, 179) sts.

**Shape V-Neck: Next Row (RS):** Work 55 (61, 67, 73, 77, 83, 89) sts, slip sts just worked to holder for left side, bind off 0 (0, 0, 0, 1, 1, 1) st, work to end—55 (61, 67, 73, 77, 83, 89) sts.

**Right Side of Neck:** Work 1 WS row.

**Dec Row (RS):** K1, k2tog, work to end—1 st dec'd at neck. Rep Dec Row every RS row 21 (20, 18, 16, 16, 14, 14) times more, then every 4th row 0 (1, 3, 5, 4, 6, 6) time(s)—33 (39, 45, 51, 55, 61, 67) sts. Work even until armhole measures 6½ (7, 7½, 8, 8, 8½, 8½)", end on RS.

**Shape Shoulder:** Bind off 4 (5, 6, 6, 7, 8, 8) sts at armhole edge 4 times, 5 (4, 6, 6, 6, 8, 8) sts once, then 4 (5, 5, 7, 7, 7, 9) sts 3 times. Fasten off.

**Left Side of Neck:** With WS facing, slip 55 (61, 67, 73, 77, 83, 89) sts from holder to larger needle. Join yarn and work 1 WS row.

**Dec Row (RS):** Work to last 3 sts, SSK, k1—1 st dec'd at neck. Rep Dec Row every RS row 21 (20, 18, 16, 16, 14, 14) times more, then every 4th row 0 (1, 3, 5, 4, 6, 6) time(s)—33 (39, 45, 51, 55, 61, 67) sts. Work even until armhole measures 6½ (7, 7½, 8, 8, 8½, 8½)", end on WS.

**Shape Shoulder:** Bind off 4 (5, 6, 6, 7, 8, 8) sts at armhole edge 4 times, 5 (4, 6, 6, 6, 8, 8) sts once, then 4 (5, 5, 7, 7, 7, 9) sts 3 times. Fasten off. Sew shoulder seams.

## SLEEVES

With RS facing, using larger needles, pick up and knit 71 (77, 83, 89, 89, 95, 95) sts along entire armhole edge (approximately 3 sts over every 4 rows). Beginning with Row 2, work even, following chart or written directions, until sleeve measures 1" from beginning, end on WS.

**Dec Row (RS):** K1, k2tog, work to last 3 sts, SSK, k1—2 sts dec'd. Rep Dec Row every 14th (10th, 8th, 6th, 6th, 6th, 6th) row 7 (10, 13, 16, 16, 14, 14) times more, then every 0 (0, 0, 0, 0, 4th 4th) row 0 (0, 0, 0, 0, 5, 5) times more—55 sts. Work even until sleeve measures 16" from beginning, end on WS. Change to smaller needles.

**Set Up Rib: Row 1 (RS):** K1, \* p1, k1, rep from \* across.

**Row 2:** P1, \* k1, p1, rep from \* across. Rep these 2 rows until sleeve measures 18" from beginning, end on WS. Bind off.

## FINISHING

Sew side and sleeve seams.

**Neck Edging:** With RS facing, using circular needle, begin at left shoulder seam, pick up and knit 48 (50, 52, 55, 56, 57, 57) sts along left front neck edge, 0 (0, 0, 0, 1, 1, 1) st over bound-off stitch, 48 (50, 52, 55, 56, 57, 57) sts along right front neck edge, then 44 (44, 44, 44, 45, 45, 45) sts across back neck edge—140 (144, 148, 154, 158, 160, 160) sts. Place marker and join for working in the round. Purl 1 round. Bind off knitwise. Weave in all ends and block as desired.

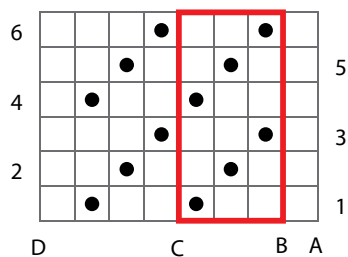

## KEY TO CHART

- knit on RS; purl on WS
- purl on RS; knit on WS
- pattern repeat

## CHART NOTES

On RS, beg at A, work to C, rep between B and C, end at D.

On WS, beg at D, work to B, rep between C and B, end at A.

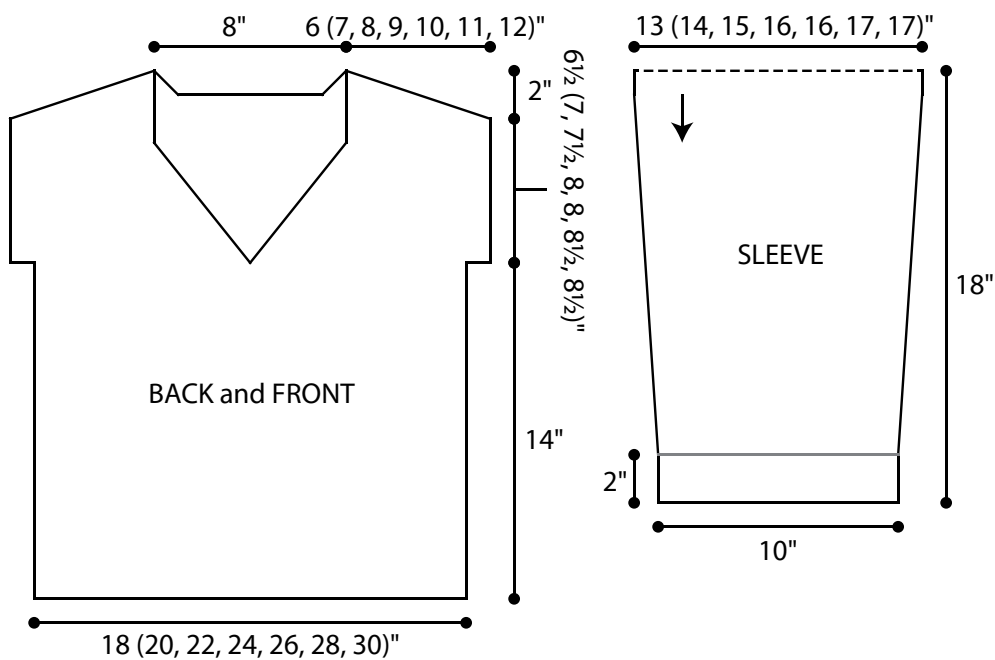

## STANDARD ABBREVIATIONS & TERMS

**beg:** beginning

**CC:** contrasting color

**CDD:** Centered Double Decrease—Slip 2 together (as if to k2tog), knit 1, pass the 2 slipped stitches over

**cn:** cable needle

**dec:** decrease

**dpn(s):** double pointed needle(s)

**end on WS:** end having just completed a Wrong Side row.

**end on RS:** end having just completed a Right Side row

**Garner St:** Knit EVERY row when working back and forth in rows. Knit 1 round, purl 1 round when working in the round.

**inc:** increase

**k:** knit

**k tbl:** knit through the back loop(s)

**k2tog:** knit 2 stitches together

**k3tog:** knit 3 stitches together

**kfb:** knit in the front and back of the next st

**LH:** left hand

**LLI:** Left Lifted Increase—Insert LH needle into the purl bump one row below the st just worked on the RH needle and knit into this st (1 st inc'd)

**M1:** Make 1—Pick up horizontal strand between stitch just worked and next stitch from front to back, place on left hand needle, knit this stitch through the back (1 stitch increased).

**M1L:** Make 1 Left—Work as for M1.

**M1p:** Make 1 purl—Pick up horizontal strand between stitch just worked and next stitch from front to back, place on left hand needle, purl this stitch through the back (1 stitch increased).

**M1pL:** Make 1 purl Left—Work as for M1p.

**M1pR:** Make 1 purl Right—Pick up horizontal strand between stitch just worked and next stitch from back to front, place on left hand needle, purl this stitch through the front (1 stitch increased).

**M1R:** Make 1 Right—Pick up horizontal strand between stitch just worked and next stitch from back to front, place on left hand needle, knit this stitch through the front (1 stitch increased).

**MC:** main color

**p:** purl

**p tbl:** purl through the back loop(s)

**p2tog:** purl 2 stitches together

**p3tog:** purl 3 stitches together

**pat(s):** pattern(s)

**pm:** place marker

**pssso:** pass slipped stitch over knit stitch

**rep:** repeat

**Rev St st:** Reverse Stockinette Stitch—Purl 1 row, knit 1 row alternately when working back and forth in rows. The purl side is the right side of the work. Purl EVERY round when working in the round.

**RH:** right hand

**RLI:** Right Lifted Increase—Insert RH needle into the purl bump of the next st on the LH needle and knit into this st (1 st inc'd)

**rnd(s):** round(s)

**RS:** right side

**sl:** slip

**sm:** slip marker

**SSK:** Slip 2 stitches knitwise, insert point of left hand needle through fronts of these 2 stitches and knit 2 together.

**SSP:** Slip 2 stitches knitwise, transfer these 2 stitches back to left hand needle, purl 2 together through the back loops.

**SSSK:** Slip 3 stitches knitwise, insert point of left hand needle through fronts of these 3 stitches and knit 3 together.

**st(s):** stitch(es)

**St st:** Stockinette Stitch—Knit 1 row, purl 1 row alternately when working back and forth in rows. The knit side is the right side of work. Knit EVERY round when working in the round.

**tbl:** through back loop(s)

**w&t:** wrap and turn, a method of concealing a hole created in short row shaping. On RS rows: With yarn held in front, slip next stitch purlwise, then bring yarn between needles to the back. Slip that same stitch back to the left needle. Turn your work. On WS Rows: With yarn held in back, slip next stitch purlwise, then bring yarn between needles to the front. Slip that same stitch back to the left needle. Turn your work. Unless otherwise indicated, each time you come to a wrapped stitch when working subsequent rows, slip the wrap back over stitch and onto needle, then work the wrap together with its accompanying stitch.

**WS:** wrong side

**wyib:** with yarn in back

**wyif:** with yarn in front

**yo:** yarn over

Love Berroco patterns?  
Sign up for our **KnitBits®** newsletter.

